

**Grooved Resilient
Swing Check Valve (H84X),
UL/FM/LPCB Approved**

OC3073.7



H84X



NSF/ANSI 61 NSF/ANSI 372

- Connection Ends: Groove to AWWA C606
- Working Pressure: 300PSI/363PSI
200PSI and 250PSI available upon request
- Temperature Range: 0°C - 80°C
- Coating: Fusion Bonded Epoxy Coating in accordance with
ANSI/AWWA C550 or painting upon request

OC3073.7



H84XF4



NSF/ANSI 61 NSF/ANSI 372

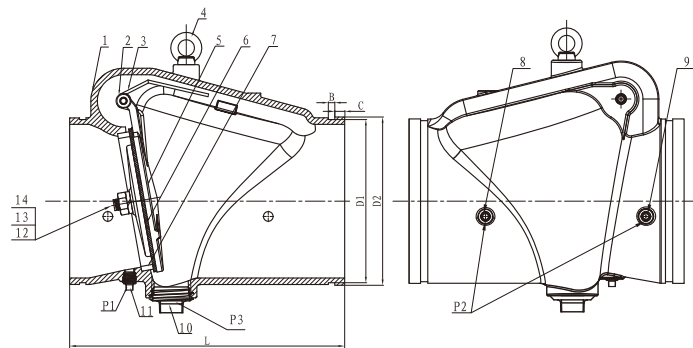

MATERIAL SPECIFICATION

| Part No. | Part | Standard Specification | Options |
|----------|-------------------|----------------------------------------------------|--------------------------------------------|
| 1 | Valve Body | ASTM A536, 65-45-12 | |
| 2 | Hinge Pin | AISI 420 | |
| 3 | Spring | AISI 304 | AISI 316 |
| 4 | Eye Bolt | Carbon Steel Zinc Plated | |
| 5 | Disc | DN50-100 AISI 304 DN150-300 ASTM A536, 65-45-12 | AISI 304 |
| 6 | Disc Sealing Ring | EPDM | |
| 7 | Seat Ring | ASTM B62 C83600 (Pressed Fit) | AISI 304, AISI 316 Pressed Fit or Threaded |
| 8 | Plug | Malleable Iron Galvanized | Bronze ASTM B584 |
| 9 | Plug | Malleable Iron Galvanized | Bronze ASTM B584 |
| 10 | Plug | Malleable Iron Galvanized | Bronze ASTM B584 |
| 11 | Plug | Malleable Iron Galvanized | Bronze ASTM B584 |
| 12 | Bolt | AISI 304 | AISI 316 |
| 13 | Washer | AISI 304 | AISI 316 |
| 14 | Nut | AISI 304 | AISI 316 |

Note: For special material request other than standard specification, please indicate clearly on the inquiry or order list.

| DN | | Dimensions(mm) | | | | | | | | |
|------|-----|----------------|--------|-------|-------|-------|-----------|-----------|---------------|-----------|
| Inch | mm | L | D1 | D2 | B | C | P1 | P3 | | P2 |
| | | | | | | | | Standard | Optional | |
| 2" | 50 | 171 | 57.15 | 60.3 | 7.93 | 15.88 | 1/2-14NPT | 1/2-14NPT | 1-11.5NPT | 3/8-18NPT |
| 2.5" | 65 | 184 | 69.09 | 73 | 7.93 | 15.88 | 1/2-14NPT | 1/2-14NPT | 1 1/4-11.5NPT | 3/8-18NPT |
| 3" | 80 | 197 | 84.94 | 88.9 | 7.93 | 15.88 | 1/2-14NPT | 1/2-14NPT | 1 1/4-11.5NPT | 3/8-18NPT |
| 4" | 100 | 210 | 110.08 | 114.3 | 9.53 | 15.88 | 1/2-14NPT | 1/2-14NPT | 2-11.5NPT | 1/2-14NPT |
| 5" | 125 | 248 | 137.03 | 141.3 | 9.53 | 15.88 | 1/2-14NPT | 1/2-14NPT | 2-11.5NPT | 1/2-14NPT |
| 6" | 150 | 324 | 163.96 | 168.3 | 9.53 | 15.88 | 1/2-14NPT | 1/2-14NPT | 2-11.5NPT | 1/2-14NPT |
| 8" | 200 | 371 | 214.4 | 219.1 | 11.13 | 19.05 | 1/2-14NPT | 1/2-14NPT | 2-11.5NPT | 1/2-14NPT |
| 10" | 250 | 457 | 268.28 | 273 | 12.7 | 19.05 | 1/2-14NPT | 1/2-14NPT | 2-11.5NPT | 1/2-14NPT |
| 12" | 300 | 535 | 318.29 | 323.9 | 12.7 | 19.05 | 1/2-14NPT | 1/2-14NPT | 2-11.5NPT | 1/2-14NPT |