

## Grooved Butterfly Valve (D81X4, D381X4)

OC2700.7CL



D81X4

NSF/ANSI 61 NSF/ANSI 372

- Design Standard: MSS SP-67
- Connection Ends: Groove to AWWA C606
- Top Flange Standard: ISO 5211  
Stem drive by keys, parallel or diagonal square or flat head
- Working Pressure: 300PSI  
175PSI, 200PSI and 250PSI available upon request
- Temperature Range: 0°C - 80°C
- Coating: Fusion Bonded Epoxy Coating in accordance with ANSI/AWWA C550 or painting upon request

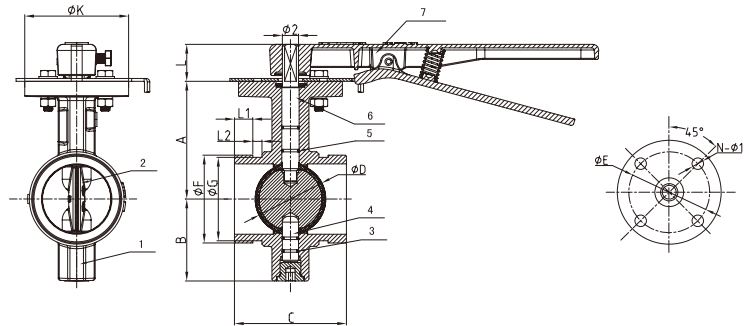

MATERIAL SPECIFICATION

Part No.	Part	Standard Specification	Options
1	Valve Body	ASTM A536, 65-45-12	
2	Disc	ASTM A536, 65-45-12+EPDM	ASTM A536, 65-45-12+NBR
3	O-Ring	NBR	EPDM
4	Stem	Stainless Steel	AISI 304, AISI 316, AISI 420, AISI 431
5	O-Ring	NBR	EPDM
6	Stem	Stainless Steel	AISI 304, AISI 316, AISI 420, AISI 431
7	Lever	ASTM A536, 65-45-12	Aluminum
8	Signal Gearbox	ASTM A536, 65-45-12	

Note: For special material request other than standard specification, please indicate clearly on the inquiry or order list.

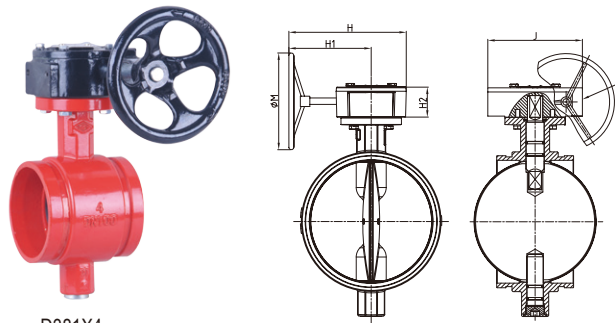

D381X4

DN		Dimensions(mm)																		
Inch	mm	A	B	C	ΦD	ΦF	ΦG	L1	L2	L	ΦK	H	H1	H2	J	ΦM	Φ2	ISO 5211	ΦE	N-Φ1
2"	50	89	65	81	50.3	60.3	57.15	15.88	7.93	32	90	206	158	52	114	150	14	F07	70	4-Φ10
2.5"	65	102	71	97	60.8	73.0	69.09	15.88	7.93	32	90	206	158	52	114	150	14	F07	70	4-Φ10
3"	80	109	81	97	76	88.9	84.94	15.88	7.93	32	90	206	158	52	114	150	14	F07	70	4-Φ10
4"	100	128	95	116	98.5	114.3	110.08	15.88	9.53	32	90	206	158	52	114	150	16	F07	70	4-Φ10
5"	125	141	111	148	122.6	141.3	137.03	15.88	9.53	32	90	206	158	52	114	150	16	F07	70	4-Φ10
6"	150	153	133	148	148	168.3	163.96	15.88	9.53	32	90	206	158	52	114	150	20	F07	70	4-Φ10
8"	200	184	164	133	199	219.1	214.4	19.05	11.10	45	125	310	239	69	167	300	26	F10	102	4-Φ12
10"	250	216	196	159	252	273.0	268.28	19.05	12.70	45	125	310	239	69	167	300	26	F10	102	4-Φ12
12"	300	254	226	165	300.5	323.9	318.29	19.05	12.70	45	125	307	229	73	190	300	28	F10	102	4-Φ12
14"	377	290	241	178	324	377	371.4	23.8	12.7	45	150	307	229	73	190	300	31.7	F12	125	4-Ø14

Note: Valve must not be installed with disc in full open position. Disc must be partly closed so that no part is protruding beyond end of valve body.