

Male NPT x Groove Connection Check Valve (H24X)



H24X



- Connection Ends: Groove to AWWA C606, Thread to ANSI/ASME B1.20.1
- Working Pressure: 363PSI ,300PSI
200PSI and 250PSI available upon request
- Temperature Range: 0°C - 80°C
- Coating: Fusion Bonded Epoxy Coating Complies with ANSI/AWWA C550 or painting upon request

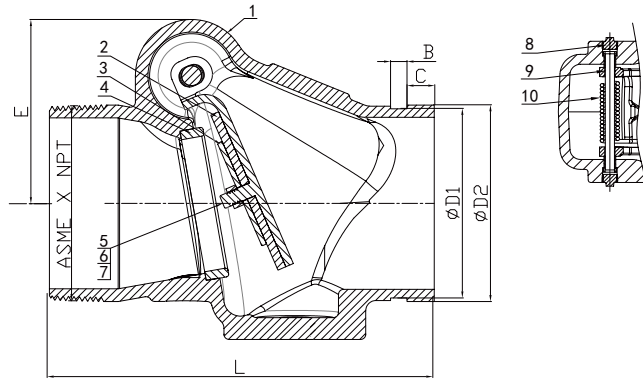

MATERIAL SPECIFICATION

Part No.	Part	Standard Specification	Options
1	Valve Body	ASTM A536 65-45-12	
2	Seal Ring	EPDM	NBR
3	Disc	AISI 304	AISI 316
4	Seat	ASTM B62 C83600	
5	Bolt	AISI 304	AISI 316
6	Washer	AISI 304	AISI 316
7	Screw Nut	AISI 304	AISI 316
8	Plug	Malleable Iron Galvanized	Bronze ASTM B584
9	Plug	Malleable Iron Galvanized	Bronze ASTM B584
10	Hinge Pin	AISI 420	AISI 304, AISI 316
11	Spring	AISI 304	AISI 316

Note: For special material request other than standard specification, please indicate clearly on the inquiry or order list.

DN		Dimensions(mm)						
Inch	mm	L	D1	D2	E	B	C	X NPT
4"	114	224	110.1	114.3	107	9.5	15.9	4-8NPT