

Flanged Resilient OS&Y  
Gate Valve (XZ41X),  
UL/FM Approved

OC3073.7  
NSF/ANSI 61 NSF/ANSI 372



XZ41X



- Connection Ends: Flange to ASME B16.1 CL 125
- Working Pressure: 300PSI  
200PSI and 250PSI available upon request
- Temperature Range: 0°C - 80°C
- Coating: Fusion Bonded Epoxy Coating Complies with ANSI/ AWWA C550



XZ41X-1

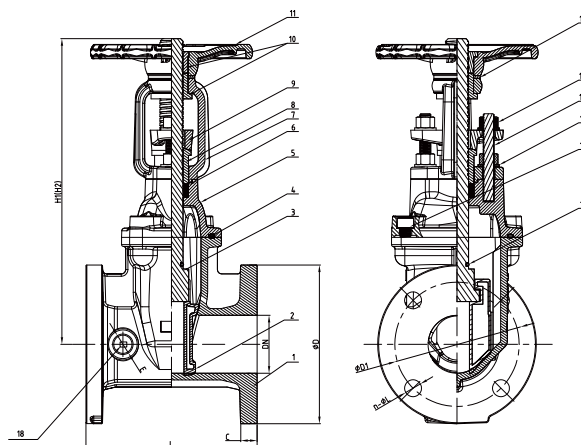

MATERIAL SPECIFICATION

Part No.	Part	Standard Specification	Options
1	Valve Body	ASTM A536, 65-45-12	
2	Resilient Wedge Disc	ASTM A536, 65-45-12+EPDM	
3	Stem	AISI 420	AISI 304, AISI 316, AISI 431, Al-bronze
4	Bonnet Gasket	EPDM	NBR
5	Bonnet	ASTM A536, 65-45-12	
6	Packing	EPDM	
7	Yoke	ASTM A536, 65-45-12	
8	Stem Bushing	Brass Hpb59-1	
9	Gland	ASTM A536, 65-45-12	
10	Stem Nut	Brass Hpb59-1	Bronze ZQSn5-5-5
11	Handwheel	ASTM A536, 65-45-12	Pressed Steel
12	Washer	Brass Hpb59-1	
13	Gland Nut	Carbon Steel Zinc Plated	AISI 304, AISI 316
14	Stud	Carbon Steel Zinc Plated	AISI 304, AISI 316
15	Flat Washer	Carbon Steel Zinc Plated	AISI 304, AISI 316
16	Bolt	Carbon Steel Zinc Plated	AISI 304, AISI 316
17	O-Ring	NBR	EPDM
18	Plug	C89833	

Note: For special material request other than standard specification, please indicate clearly on the inquiry or order list.  
Size 2"-5" with 1pc of 1/2" bronze NPT tapping plug, size 6"-12 with 1pc of 3/4" bronze NPT tapping plug.

DN		Dimensions(mm)						
Inch	mm	L	H1(Close)	H2(Open)	D	D1	C	n-ΦL
2"	50	178	348	400	152	120.7	16.0	4-Ø19.1
2.5"	65	190	373	440	178	139.7	17.5	4-Ø19.1
3"	80	203	408	490	191	152.4	19.1	4-Ø19.1
4"	100	229	471	573	229	190.5	19.1	8-Ø19.1
5"	125	254	541	665	254	215.9	19.1	8-Ø22.2
6"	150	267	601	755	279	241.3	19.1	8-Ø22.2
8"	200	292	774	975	343	298.5	22.2	8-Ø22.2
10"	250	330	939	1193	406	362.0	23.8	12-Ø25.4
12"	300	356	1065	1370	483	431.8	25.4	12-Ø25.4
14"	350	381	1403	1817	533	476.3	25.4	12-Ø28.6
16"	400	406	1403	1817	597	539.8	25.4	16-Ø28.6
18"	450	432	1788	2308	635	577.9	25.4	16-Ø31.8
20"	500	457	1809	2329	699	635	28.6	20-Ø31.8
24"	600	508	2025	2649	813	749.3	30.1	20-Ø34.9