

Flanged x Grooved
Resilient OS&Y Gate Valve (XZ51X),
UL/FM Approved

OC3073.7
NSF/ANSI 61 NSF/ANSI 372

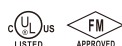

XZ51X



- Connection Ends: Flange to ASME B16.1 CL 125
Groove to AWWA C606
- Working Pressure: 300PSI
200PSI and 250PSI available upon request
- Temperature Range: 0°C - 80°C
- Coating: Fusion Bonded Epoxy Coating Complies with
ANSI/AWWA C550

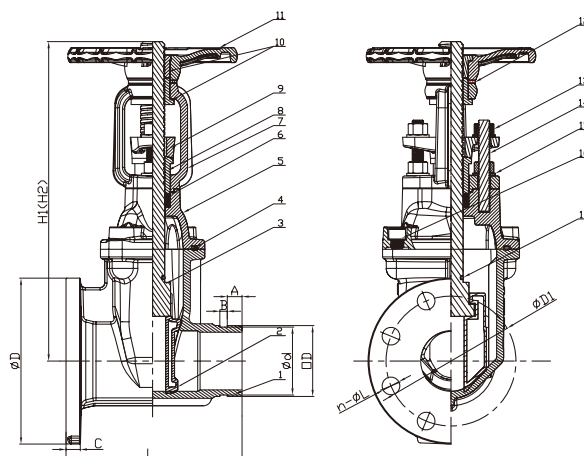

MATERIAL SPECIFICATION

Part No.	Part	Standard Specification	Options
1	Valve Body	ASTM A536, 65-45-12	
2	Resilient Wedge Disc	ASTM A536, 65-45-12+EPDM	
3	Stem	Stainless Steel	AISI 304, AISI 316, AISI 420, AISI 431
4	Bonnet Gasket	EPDM	
5	Bonnet	ASTM A536, 65-45-12	
6	Stem Packing	EPDM	
7	Yoke	ASTM A536, 65-45-12	
8	Stem Bushing	Brass Hpb59-1	
9	Gland	ASTM A536, 65-45-12	
10	Stem Nut	Brass Hpb59-1	Bronze ZQSn5-5-5
11	Handwheel	ASTM A536, 65-45-12	Pressed Steel
12	Washer	Brass Hpb59-1	
13	Gland Nut	Carbon Steel Zinc Plated	AISI 304, AISI 316
14	Stud	Carbon Steel Zinc Plated	AISI 304, AISI 316
15	Flat Washer	Carbon Steel Zinc Plated	AISI 304, AISI 316
16	Bolt	Carbon Steel Zinc Plated	AISI 304, AISI 316
17	O-Ring	NBR	EPDM

Note: For special material request other than standard specification, please indicate clearly on the inquiry or order list.
Size 2"-5" with 1pc of 1/2" bronze NPT tapping plug, size 6"-12 with 1pc of 3/4" bronze NPT tapping plug.

DN		Dimensions(mm)									
Inch	mm	L	H1(Close)	H2(Open)	D	D1	C	n-ΦL	OD	d	A
2"	50	178	348	400	152	120.7	16.0	4-Φ19.1	60.3	57.15	15.88
2.5"	65	190	373	440	178	139.7	17.5	4-Φ19.1	73.0	69.09	15.88
3"	80	203	408	490	191	152.4	19.1	4-Φ19.1	88.9	84.94	15.88
4"	100	229	471	573	229	190.5	19.1	8-Φ19.1	114.3	110.08	15.88
5"	125	254	541	665	254	215.9	19.1	8-Φ22.2	141.3	137.03	15.88
6"	150	267	601	755	279	241.3	19.1	8-Φ22.2	168.3	163.96	15.88
8"	200	292	774	975	343	298.5	22.2	8-Φ22.2	219.1	214.4	19.05
10"	250	330	1029	1283	406	362.0	23.8	12-Φ25.4	273.0	268.28	19.05
12"	300	356	1065	1370	483	431.8	25.4	12-Φ25.4	323.9	318.29	19.05