

Flanged Resilient Swing Check Valve (H44X2/ H44X2A), UL/FM/LPCB Approved

00C3073.7



H44X2



NSF/ANSI 61 NSF/ANSI 372

- Connection Ends: Flange to ASME B16.1
- Working Pressure: 300PSI/363PSI
200PSI and 250PSI available upon request
- Temperature Range: 0°C - 80°C
- Coating: Fusion Bonded Epoxy Coating in accordance with ANSI/AWWA C550

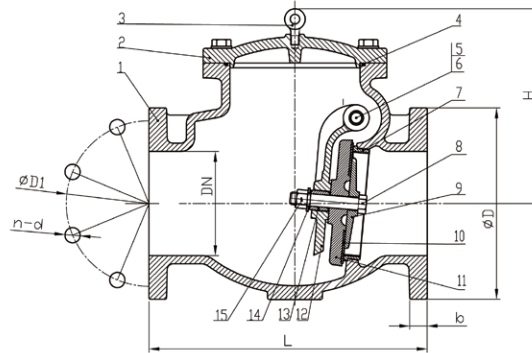

MATERIAL SPECIFICATION

Part No.	Part	Standard Specification	Options
1	Valve Body	ASTM A536, 65-45-12	
2	Bonnet	ASTM A536, 65-45-12	
3	Eye Bolt	Carbon Steel Zinc Plated	
4	O-Ring	NBR	EPDM
5	Hinge Pin	AISI 304	
6	Hinge Bushing	Brass ASTM B16 C36000/Hpb63-3	
7	Seat Ring	Bronze ASTM B62 C83600/ZQSn5-5-5(Pressed Fit)	AISI 304, AISI 316 Pressed Fit or Threaded
8	Disc Seat Bolt	AISI 304	
9	Retainer Washer	Bronze ASTM B62 C83600/ZQSn5-5-5	
10	Disc Sealing Ring	EPDM	AISI 304, AISI 316, Bronze ASTM B62
11	Disc	ASTM A536, 65-45-12	
12	Clapper Arm	ASTM A536, 65-45-12	
13	Stud Bushing	Brass ASTM B16 C36000/Hpb63-3	
14	O-Ring	NBR	EPDM
15	Nut	AISI 304	AISI 316

Note: For special material request other than standard specification, please indicate clearly on the inquiry or order list.

DN		Dimensions(mm)						
Inch	mm	L		D	D1	b	n-Φd	H
		Standard	Optional					
2"	50	203	203	152	120.5	16	4-Φ19.1	133
2.5"	65	254	216	178	139.5	17.5	4-Φ19.1	150
3"	80	278	241	191	152.5	19	4-Φ19.1	150
4"	100	330	292	229	190.5	24	8-Φ19.1	218
6"	150	406	356	279	241.5	25.5	8-Φ22.2	290
8"	200	495	495	343	298.5	28.5	8-Φ22.2	330
10"	250	622	622	406	362	30.5	12-Φ25.4	350
12"	300	660	698	483	432	32	12-Φ25.4	376

Note: Standard of Face-to-Face in according with AWWA C508.
Optional of Face-to-Face in according with ASME B16.10.